



A510

Advanced Current Vector Control Drive



**TAIWAN
EXCELLENCE
2012**

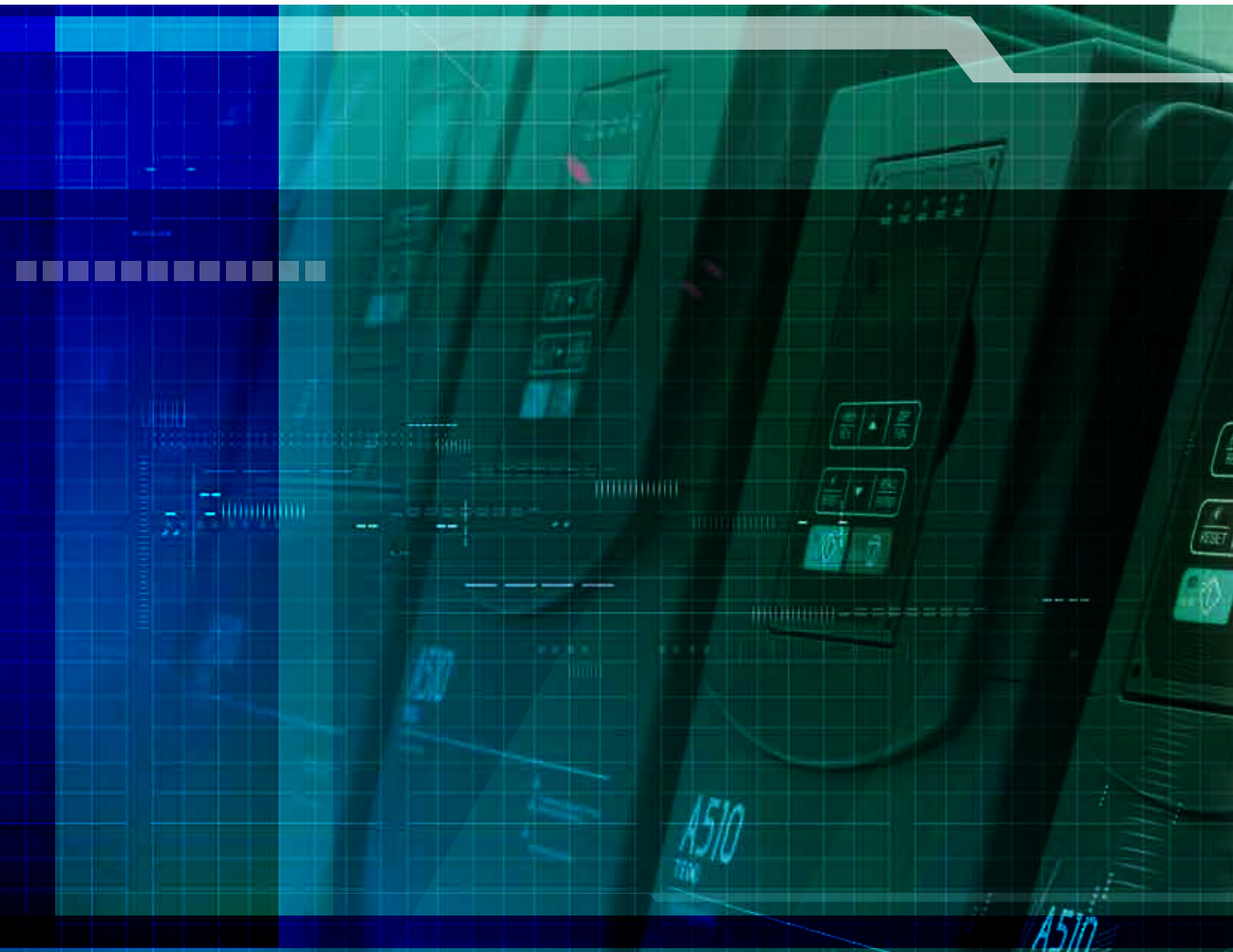

The Complete Motor Control Solution



Contents

Features.....	03
Applications.....	05
Selection Guide.....	06
Wiring Diagram.....	07
Specifications.....	08
Dimensions.....	10
Accessories.....	12

DUAL CORE PROCESSORS

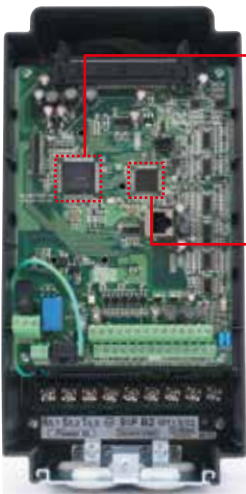

ASIC *Above frame2 models
Prevents inrush current damage to IGBT module. Enhances the reliability and life expectancy of motor drive.

32Bit MCU
Mass computing capability for advanced current vector control technology. Minimizes the internal loop time for higher control response.

Enhanced Performance & Reliability!

HIGH EFFICIENCY PM MOTOR DRIVING

- Simple parameter settings for easy switching between induction and permanent magnet motors.
- High performance current vector control for induction and permanent magnet motors.



Induction Motor (IM)

- Cost Effective
- Mechanical Robust



Surface Permanent Magnet Motor (SPM)

- Highly Efficient
- Compact Size
- Low Cogging Torque



Interior Permanent Magnet Motor (IPM)

- Highly Efficient
- Compact Size
- With Reluctance Torque

ADVANCED MOTOR AUTO-TUNE FUNCTION

Multiple Auto-tune Modes

Rotational auto-tune mode	Rotary-type auto-tune for higher performance for precise control.
Static auto-tune mode	The motor shaft will be locked in static auto-tune mode.
Stator resistance measurement	Auto measure the resistor within cable and compensate accordingly.

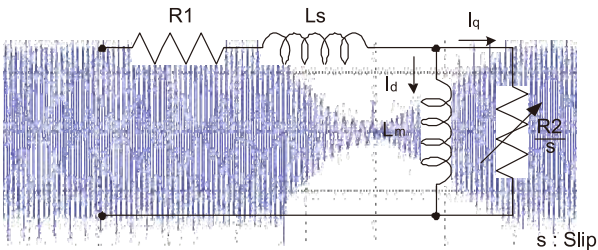

Motor Equivalent Circuit

**5th
Kernel**

A510 is loaded with 5th generation kernel has the most advanced motor tuning function to build accurate motor equivalent model automatically.

Optimized current vector control performance provides faster commissioning.

200% 0.5Hz STARTING TORQUE

Sensorless Vector (SLV) control mode achieves incredible 200% torque performance at extreme low speed 0.5Hz. Provides stable control experience for wide range of applications.

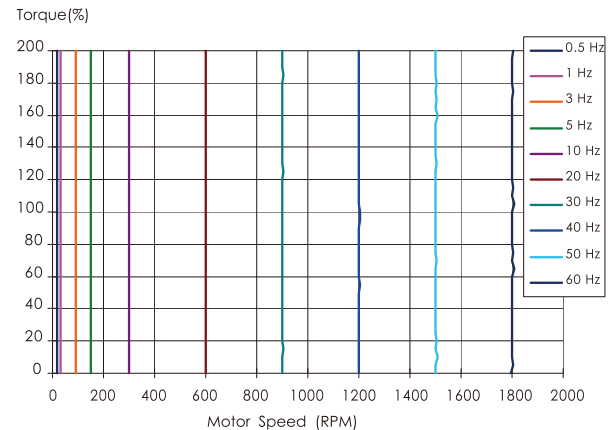

Sensor Vector Mode (SV) can output 200% holding torque.

CONFORMITY TO GLOBAL STANDARDS

- Conformity to RoHS directive and international recognized certification

RoHS



DOWN SIZE DESIGN

- New design with effective heat dissipation reduced size requiring less panel space.



*based on A510 400V 7.5HP comparison

HARDWARE SWITCH OFF FUNCTION

- Built-in high reliable hardware circuit for PWM cutoff.

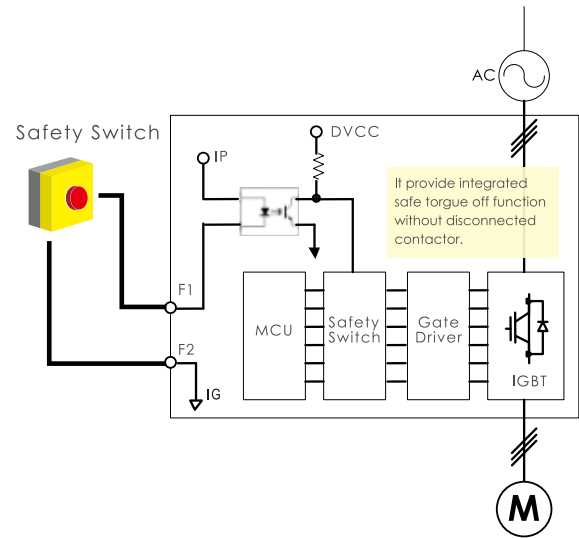

ULTRA LOW MOTOR NOISE

Traditional PWM modulation method

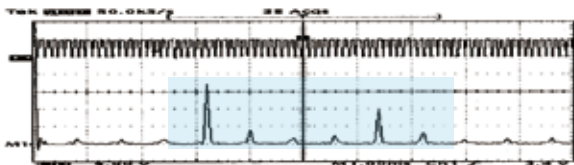

Unique Soft PWM modulation technology lowers the audible motor noise for quieter industrial environment

Soft PWM modulation method

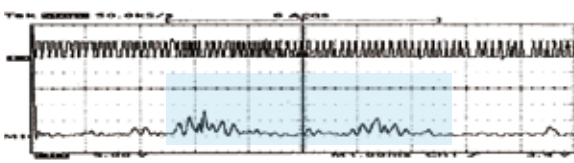

INTELLIGENT OVER VOLTAGE SUPPRESSION

- Suppress over voltage caused by regenerative loads and redirect regenerative energy back to the load. Intelligent overvoltage suppression will not only protect the drive but also no need for costly braking units.

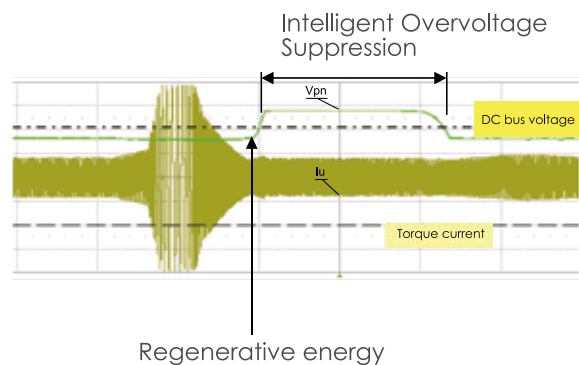

The Complete Motor Control Solution

with powers for a wide range of applications



Gravitational Handling Equipment

| Crane, Elevator

Metal Processing Machine

| Press, Lathes

Plastics/Rubber Processing Machine

| Extruder, Injection Molding Machine

Tension Control Equipment

| Printing Machine, Reeling Machine

Textile Machine

| Dyeing and Finishing Machine

Wire/Cable Making Machine

| Wire Drawing Machine

SELECTION GUIDE

Dual rating design for heavy duty and normal duty applications.

ND. Selection Guide
Overload Capability Up To 120%/60sec

Driving higher horsepower motor in normal duty mode includes fans, pumps, HVAC, etc.

Example:
Select A510-2002-H model for 3HP motor in pump application. Sets 00-27=1 (ND Mode)
*Motor parameters need to be adjusted.

HD. Selection Guide
Overload Capability Up To 150%/60sec and 200%/2sec

Driving the same horsepower motor in heavy duty mode includes lifts, press, machine tools, etc.

Example:
Select A510-2015-H3 model for 15HP motor in conveyor application. Sets 00-27=0 (HD Mode)

Maximum Applicable Motor (HP) (kW)		Three-Phase 200V				Three-Phase 400V			
		Normal Duty (ND)		Heavy Duty (HD)		Normal Duty (ND)		Heavy Duty (HD)	
		A510 Model	Rated Output Current	A510 Model	Rated Output Current	A510 Model	Rated Output Current	A510 Model	Rated Output Current
1	0.75			A510-2001-H	5A			A510-4001-H3(F)	3.4A
1.5	1.1	A510-2001-H	6A						
2	1.5			A510-2002-H	8A	A510-4001-H3(F)	4.1A	A510-4002-H3(F)	4.2A
3	2.2	A510-2002-H	9.6A	A510-2003-H	11A	A510-4002-H3(F)	5.4A	A510-4003-H3(F)	5.5A
5	3.7	A510-2003-H	12A	A510-2005-H3	17.5A	A510-4003-H3(F)	6.9A	A510-4005-H3(F)	9.2A
7.5	5.5	A510-2005-H3	21A	A510-2008-H3	25A	A510-4005-H3(F)	11.1A	A510-4008-H3(F)	14.8A
10	7.5	A510-2008-H3	30A	A510-2010-H3	33A	A510-4008-H3(F)	17.5A	A510-4010-H3(F)	18A
15	11	A510-2010-H3	40A	A510-2015-H3	47A	A510-4010-H3(F)	23A	A510-4015-H3(F)	24A
20	15	A510-2015-H3	56A	A510-2020-H3	60A	A510-4015-H3(F)	31A	A510-4020-H3(F)	31A
25	18.5	A510-2020-H3	69A	A510-2025-H3	73A	A510-4020-H3(F)	38A	A510-4025-H3(F)	39A
30	22	A510-2025-H3	80A	A510-2030-H3	85A	A510-4025-H3(F)	44A	A510-4030-H3(F)	45A
40	30	A510-2030-H3	110A	A510-2040-H3	115A	A510-4030-H3(F)	58A	A510-4040-H3(F)	60A
50	37	A510-2040-H3	138A	A510-2050-H3	145A	A510-4040-H3(F)	72A	A510-4050-H3(F)	75A
60	45	A510-2050-H3	169A	A510-2060-H3	180A	A510-4050-H3(F)	88A	A510-4060-H3(F)	91A
75	55	A510-2060-H3	200A	A510-2075-H3	215A	A510-4060-H3(F)	103A	A510-4075-H3	118A
100	75	A510-2075-H3	250A	A510-2100-H3	283A	A510-4075-H3	145A	A510-4100-H3	150A
125	94	A510-2100-H3	312A	A510-2125-H3	346A	A510-4100-H3	165A	A510-4125-H3	180A
150	112	A510-2125-H3	400A	A510-2150-H3	415A	A510-4125-H3	208A	A510-4150-H3	216A
175	130	A510-2150-H3	450A			A510-4150-H3	250A	A510-4175-H3	260A
215	160					A510-4175-H3	296A	A510-4215-H3	295A
250	185					A510-4215-H3	328A	A510-4250-H3	370A
270	200					A510-4250-H3	435A		
300	220							A510-4300-H3	450A
335	250					A510-4300-H3	515A		
375	280							A510-4375-H3	523A
425	315					A510-4375-H3	585A	A510-4425-H3	585A

Model Identification

A510	-	2		001	-	H		3		F
A510 Series		Input Voltage 2 : 200V Class 4 : 400V Class		Horse Power 001 : 1HP 425 : 425HP		Type H : Standard Type (LED Display) C : Graphic Type (LCD Display)		Power Supply Blank : Single/Three-Phase 3 : Three-Phase		Noise Filter Blank : None F : Built-in

Notes: "-A" added behind the model name is the dedicated model.

WIRING DIAGRAM

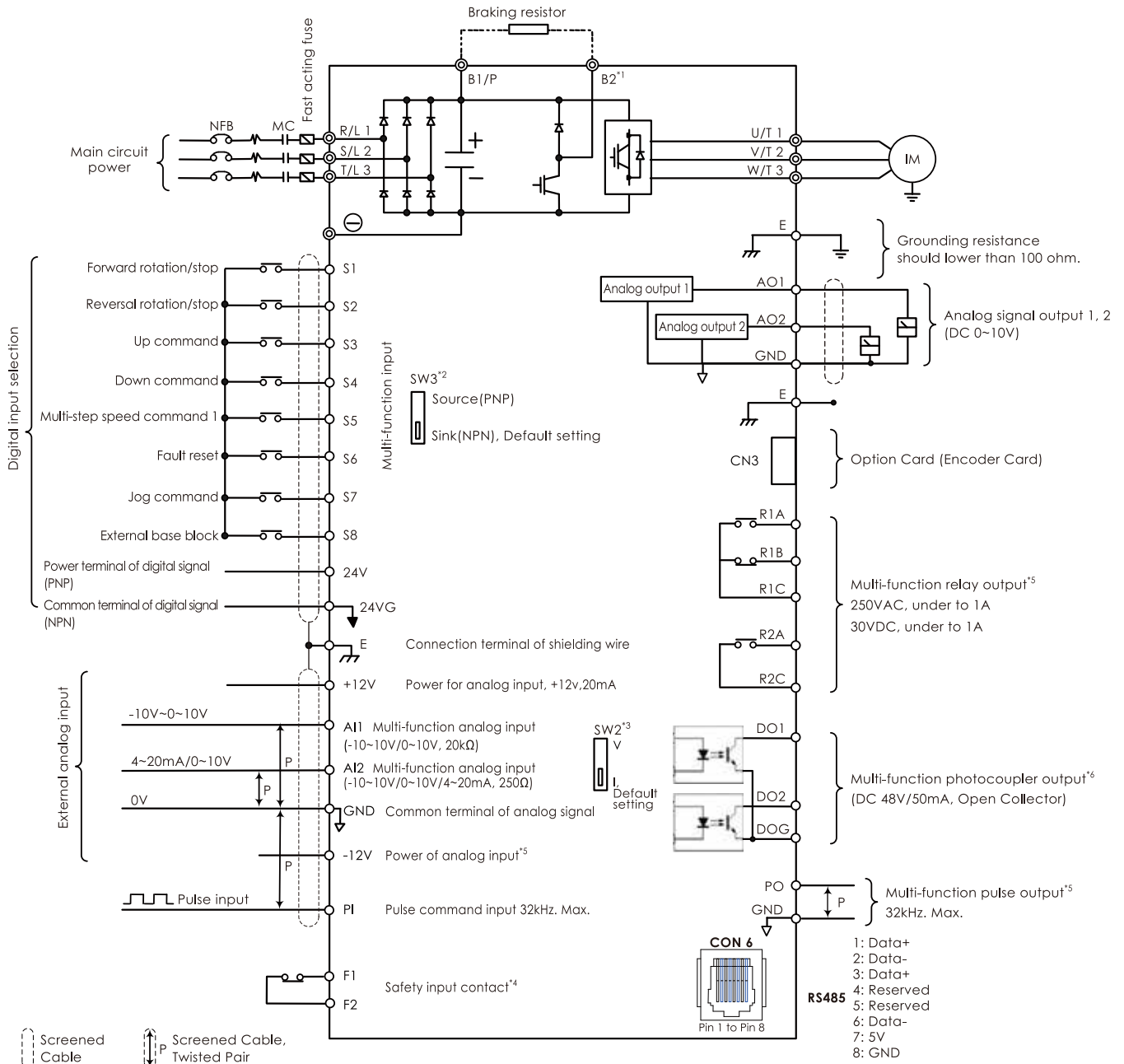

Notes:

- *1: The main circuit of 200V 1~25HP and 400V 1~30HP (included) with built-in braking transistor provide terminal B2. The braking resistor can be connected directly between B1 and B2. Optional braking module is available for the other models.
- *2: The multi-function digital input terminals S1~S8 can be set to Source (PNP) or Sink (NPN) mode by SW3.
- *3: Multi-function analog input 2 (AI2) can be set to the voltage command input (0~10V/-10~10V) or the current command input (4~20mA) through SW2.
- *4: When integrated safety function is NOT used, connect a link across terminals F1 & F2 for the inverter output to function. External safety circuits can be interfaced with inverter using terminals F1 and F2.
- *5: Terminals -12V, R2A-R2C and PO-GND are provided for 200V 3HP and 400V 5HP ratings or above.
- *6: Terminals DO2 and DOE are provided for 200V 2HP and 400V 3HP ratings or below.
- *7: Both 200V class 50HP~150HP and 400V class 75HP~425HP have built-in DC reactors.

BASIC SPECIFICATIONS

200V Class

Inverter Capacity (HP)			1	2	3	5	7.5	10	15	20	25	30	40	50	60	75	100	125	150	
Output Rating _s	HD*3	Rated Output Capacity (KVA)	1.9	3	4.2	6.7	9.5	12.6	17.9	22.9	27.8	32.4	43.8	55.3	68.6	81.9	108	132	158	
		Rated Output Current (A)	5	8	11	17.5	25	33	47	60	73	85	115	145	180	215	283	346	415	
		Maximum Applicable Motor*1 HP (KW)	1 (0.75)	2 (1.5)	3 (2.2)	5 (3.7)	7.5 (5.5)	10 (7.5)	15 (11)	20 (15)	25 (18.5)	30 (22)	40 (30)	50 (37)	60 (45)	75 (55)	100 (75)	125 (90)	150 (110)	
	ND*4	Rated Output Capacity (KVA)	2.3	3.7	4.6	8.0	11.4	15.2	21.3	26.3	30.1	41.9	52.6	64.4	76.2	95.3	118.9	137.2	172	
		Rated Output Current (A)	6	9.6	12	21	30	40	56	69	80	110	138	169	200	250	312	400	450	
		Maximum Applicable Motor*1 HP (KW)	1.5 (1.1)	3 (2.2)	4 (3)	7.5 (5.5)	10 (7.5)	15 (11)	20 (15)	25 (18.5)	30 (22)	40 (30)	50 (37)	60 (45)	75 (55)	100 (75)	125 (90)	150 (110)	175 (130)	
Maximum Output Voltage (V)		Three-Phase, 200V to 240V																		
Maximum Output Frequency (Hz)		0.1~599.0Hz																		
Input Power	Rated Voltage, Frequency		Single/Three-Phase, 200V to 240V, 50/60Hz						Three-Phase, 200V to 240V, 50/60Hz											
	Allowable Voltage Fluctuation		-15% ~ +10%																	
	Allowable Frequency Fluctuation		±5%																	
Braking Transistor		Built-in									Option (Braking Module)									
Frame Size		1	2	3	4	5	6	7	8											

400V Class

Inverter Capacity (HP)			1	2	3	5	7.5	10	15	20	25	30	40	50	60	75	100	125	150	175	215	250	300	375	425	
Output Rating _s	HD*3	Rated Output Capacity (KVA)	2.6	3.2	4.2	7	11.3	13.7	18.3	23.6	29.7	34.3	45.7	57.2	69.3	89.9	114	137	165	198	225	282	343	400	446	
		Rated Output Current (A)	3.4	4.2	5.5	9.2	14.8	18	24	31	39	45	60	75	91	118	150	180	216	260	295	370	450	523	585	
		Maximum Applicable Motor*1 HP (KW)	1 (0.75)	2 (1.5)	3 (2.2)	5 (3.7)	7.5 (5.5)	10 (7.5)	15 (11)	20 (15)	25 (18.5)	30 (22)	40 (30)	50 (37)	60 (45)	75 (55)	100 (75)	125 (90)	150 (110)	175 (132)	215 (160)	250 (185)	300 (220)	375 (280)	425 (315)	
	ND*4	Rated Output Capacity (KVA)	3.1	4.1	5.3	8.5	13.3	17.5	23.6	29.0	33.5	44.2	54.9	67.1	78.5	111	126	159	191	226	250	332	393	446	446	
		Rated Output Current (A)	4.1	5.4	6.9	11.1	17.5	23	31	38	44	58	72	88	103	145	165	208	250	296	328	435	515	585	585	
		Maximum Applicable Motor*1 HP (KW)	2 (1.5)	3 (2.2)	4 (3)	7.5 (5.5)	10 (7.5)	15 (11)	20 (15)	25 (18.5)	30 (22)	40 (30)	50 (37)	60 (45)	75 (55)	100 (75)	125 (90)	150 (110)	175 (132)	215 (160)	250 (185)	270 (200)	335 (250)	425 (315)	425 (315)	
Maximum Output Voltage (V)		Three-Phase, 380V to 480V																								
Maximum Output Frequency (Hz)		0.1~599.0Hz																								
Input Power	Rated Voltage, Frequency		Three-Phase, 380V to 480V, 50/60Hz																							
	Allowable Voltage Fluctuation		-15% ~ +10%																							
	Allowable Frequency Fluctuation		±5%																							
Braking Transistor		Built-in									Option (Braking Module)															
Frame Size		1	2	3	4	5	6	7	8																	

Notes:

- *1. Based on the standard 4-pole induction motor. The selected inverter must have a higher output current rating than the motor.
- *2. The default setting of A510 takes HD (heavy duty mode) as the base. To switch A510 to ND (normal duty mode) set parameter (00-27) to 1. When switching to ND (normal duty mode), the frequency will change to 2kHz.
- *3. The default setting of carrier frequency in HD mode is shown in right side table, if the setting value is higher than default setting, de-rating may be required.
- *4. The default setting of carrier frequency in ND mode is 2kHz, if the setting value is higher than default setting, de-rating may be required.
- *5. If control mode is set to SLV mode and maximum frequency is larger than 80Hz, the carrier frequency range is 2~8kHz.

Inverter Voltage and Capacity		HD mode carrier freq range	HD mode carrier freq default setting
200V class	400V class		
1~20HP	1~30HP	2~16kHz	8kHz
25HP	-	2~12kHz	6kHz
30~40HP	40~50HP	2~12kHz ^{*5}	5kHz
50~100HP	60~175HP	2~10kHz ^{*5}	5kHz
-	215HP	2~8kHz	3kHz
125~150HP	-	2~5kHz	5kHz
	250~375HP	2~5kHz	4kHz
	425HP	2~5kHz	2kHz

GENERAL SPECIFICATIONS

Control Characteristics	Display	LED keypad with 5-digits seven-segment display (LCD keypad option)
	Control Modes	V/F, V/F+PG, SLV, SV, PMSV (SVPWM Modulation)
	Output Frequency	0.1Hz~599.0Hz
	Frequency Accuracy	Digital references: $\pm 0.01\%$ (-10 to +40°C), Analog references: $\pm 0.1\%$ (25°C $\pm 10^\circ\text{C}$)
	Speed Control Accuracy	$\pm 0.1\%$ (Sensor Vector Control Mode, SV) ^{*2} · $\pm 0.5\%$ (Sensorless Vector Control Mode, SLV) ^{*2}
	Frequency Setting Resolution	Digital References: 0.01Hz, Analog References: 0.06Hz at 60Hz
	Output Frequency Resolution	0.01Hz
	Overload Tolerance	Heavy Duty Mode (HD.) : 150% rated current for 60sec, 200% rated current for 2 sec. (Factory default) Normal Duty Mode (ND.) : 120% rated current for 60sec
	Frequency Setting Signal	0 to +10V, -10V to +10V, 4 to 20mA or pulse train input
	Acceleration / Deceleration Time	0.0~6000.0 sec (separately set acceleration and deceleration time)
	Voltage / Frequency Characteristics	15 fixed and one customized v/f pattern
	Braking Torque	Approximate 20%
Main Control Functions	Auto tuning, Zero Servo, Torque Control, Position Control, Droop, Soft-PWM, Over-Voltage Protection, Dynamic Braking, Speed Search, Frequency Traversing, Momentary Power Loss Restart, PID Control, Automatic Torque Compensation, Slip Compensation, RS-485 Communication, Close Loop Control with PG, Simple PLC Function, Two Analog Output, Safety input contact	
Other Functions	Records of Power ON and Operation Time, Four Fault History Records and Latest Fault State Record, Energy-Saving Function, Phase Loss Protection, DC Braking, Dwell, S Curve Acceleration and Deceleration, Up / Down Operation, Modbus Communication Protocol, Output of Pulse Multiple, Display of Engineering Unit, SINK / SOURCE Selection	
Protection Functions	Stall Prevention	Current level can be adjusted. (In acceleration or constant speed, it can be set separately. In deceleration, it can be set with or without stall protection)
	Over Current (OC) and Output Short-Circuit (SC) Protection	It stops when the current exceeds 200% of the inverter rated current.
	Inverter Overload Protection (OL2)	Inverter will be stopped when the output is higher than below conditions. Heavy Duty Mode (HD.) : 150% rated current for 60sec, 200% rated current for 2 sec. (Factory default), Carrier frequency is from 2kHz to 8kHz. Normal Duty Mode (ND.) : 120% rated current for 60sec, Carrier frequency is 2kHz.
	Motor Overload Protection (OL1)	Electrical overload protection curve
	Over Voltage Protection (OV)	If the main circuit DC voltage is over 410V (200V class) / 820V (400V class), the motor stops running.
	Under Voltage (UV)	If the main circuit DC voltage is under 190V (200V class) / 380V (400V class), the motor stops running.
	Momentary Power Loss Restart	Power loss exceeds 15ms You can set the function of momentary power loss restart to up to 2 sec
	Overheat Protection (OH)	Thermistor sensor on heatsink
	Ground Fault Protection (GF)	Protection by current detection circuit
	Charge Indicator	When main circuit DC voltage $\geq 50\text{V}$, the CHARGE LED is on.
	Output Phase Loss Protection (OPL)	If the OPL function acts, the motor stops rotation automatically
	Location	Indoor (Protected from corrosive gases and dust)
Environment Specification	Ambient Temperature	-10 to +40°C without de-rating (IP20/NEMA1), -10 to +50°C (IP00), with de-rating, its maximum operation temperature is 60°C
	Storage Temperature	-20~+70°C
	Humidity	95%RH or less (no condensation)
	Altitude and Vibration	Altitude of 1000 meters or lower ; 1.0G, in compliance with IEC 60068-2-6
Communication Function	Built-in RS-485 as standard (Modbus protocol with standard RJ45)	
Electromagnetic Interference (EMI)	In compliance with EN61800-3 standard, 400V 60HP or below can be built in.	
Electromagnetic Compatibility (EMS)	In compliance with EN61800-3 standard	
Certification	CE	In compliance with EN61800-3 (CE & RE) and EN61800-5-1 (LVD)
	UL	UL508C
Option Card	Open collector type(IM) , line driver type(IM) and Line driver type for PM motor	

Notes:

*1. The maximum output frequency of each control modes is different, please read user manual for more details.

*2. Speed control accuracy will be influenced when the motor and installation condition are different.

*3. IP21 models are available, if necessary, please contact with our sales.

DIMENSIONS

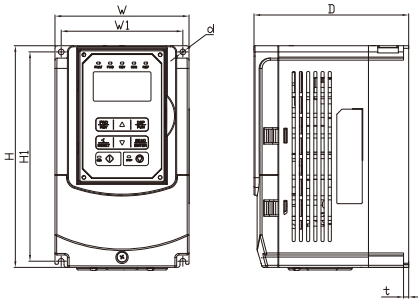

Figure A

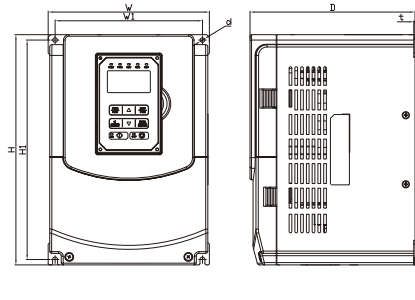

Figure B

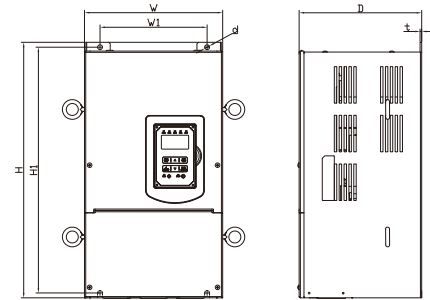

Figure C

Figure	Enclosure	Frame	Models	Dimensions (mm)							Weight (kg)
				W	H	D	W1	H1	t	d	
A	IP20	Frame 1	A510-2001-H	130	215	150	118	203	5	M5	2.2
			A510-2002-H								
			A510-4001-H3								
			A510-4002-H3								
B	IP20	Frame 2	A510-2003-H	140	279	177	122	267	7	M6	3.8
			A510-2005-H3								
			A510-4005-H3								
			A510-4008-H3								
		Frame 3	A510-2008-H3	210	300	215	192	286	1.6	M6	6.2
			A510-2010-H3								
			A510-4010-H3								
		Frame 4	A510-4015-H3	265	360	225	245	340	1.6	M8	10
			A510-2015-H3								
			A510-2020-H3								
A510-2025-H3											
C	IP20	Frame 5	A510-2030-H3	284	525	252	220	505	1.6	M8	30
			A510-2040-H3								
			A510-4040-H3								
			A510-4050-H3								
			A510-4060-H3								

Figure D

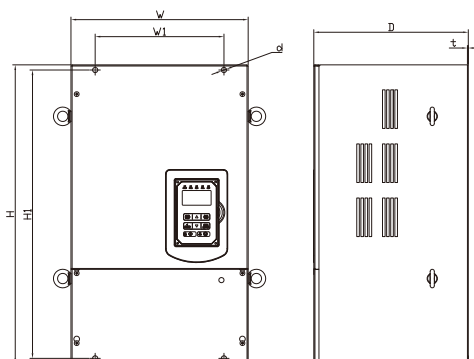

Figure E

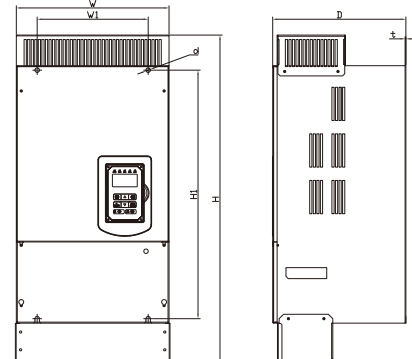

Figure	Enclosure	Frame	Models	Dimensions (mm)							Weight (kg)
				W	H	D	W1	H1	t	d	
D	IP00	Frame 6	A510-2050-H3	344	580	300	250	560	1.6	M10	40.5
			A510-2060-H3								
			A510-4075-H3								
			A510-4100-H3								
E	IP20	Frame 6	A510-2050-H3	348.5	740	300	250	560	1.6	M10	44
			A510-2060-H3								
			A510-4075-H3								
			A510-4100-H3								
D	IP00	Frame 7	A510-2075-H3	459	790	324.5	320	760	1.6	M10	74
			A510-2100-H3								
			A510-4125-H3								
			A510-4150-H3								
			A510-4175-H3								
A510-4215-H3											
E	IP20	Frame 7	A510-2075-H3	463.5	1105	324.5	320	760	1.6	M10	81
			A510-2100-H3								
			A510-4125-H3								
			A510-4150-H3								
			A510-4175-H3								
A510-4215-H3											

Figure F

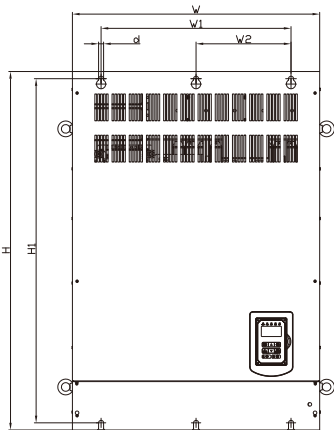

Figure G

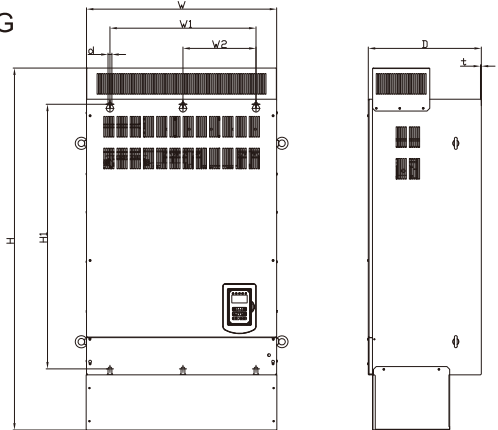

Figure	Enclosure	Frame	Models	Dimensions (mm)							Weight (kg)	
				W	H	D	W1	W2	H1	t		d
F	IP00	Frame 8	A510-2125-H3	690	1000	410	530	265	960	1.6	M12	184
			A510-2150-H3									
			A510-4250-H3									
			A510-4270-H3									
			A510-4300-H3									
			A510-4375-H3									
A510-4425-H3												
G	IP20	Frame 8	A510-2125-H3	690	1313	410	530	265	960	1.6	M12	194
			A510-2150-H3									
			A510-4250-H3									
			A510-4270-H3									
			A510-4300-H3									
A510-4375-H3												
A510-4425-H3												

* The enclosure type of IP00 model is standard for frame 6 to frame 8. It is required to purchase the installation accessories if user selects the enclosure type of IP20 model.

Frame 6	JN5-NK-A06
Frame 7	JN5-NK-A07
Frame 8	JN5-NK-A08

ACCESSORIES

Encoder Feedback Option Card

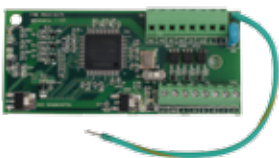
JN5-PG-O	Terminals	Description
 <p>■ For IM motor ■ Support Open Collector type and Complementary type pulse signal</p>	Vcc	Power Supply for PG: 12V/5V±5%, 200mA
	IG24	Power Source and Input Signal Common
	A, B, Z	PG Signal Input Terminal (Open Collector Type)
	AO, BO, ZO	Pulse monitor output: Open Collector Type, 24V, 30mA
	E	Grounding Terminal

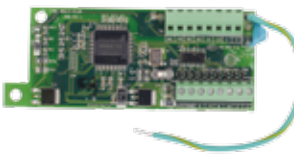
JN5-PG-L	Terminals	Description
 <p>■ For IM motor ■ Support Line Driver type pulse signal</p>	Vcc	Power Supply for PG: 12V/5V±5%, 200mA
	GND	Power Source and Input Signal Common
	A, / A, B, / B, Z, / Z	PG Signal Input Terminal (Line Driver Type), RS-422 Level Input
	AO, / AO, BO, / BO, ZO, / ZO	Pulse monitor output: Line Driver Type, RS-422 Level Input
	E	Grounding Terminal

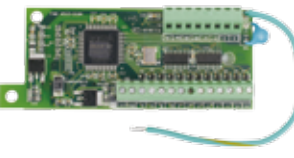
JN5-PG-PM	Terminals	Description
 <p>■ For PM motor ■ Support Line Driver type pulse signal</p>	Vcc	Power Supply for PG: 5V±5%, 200mA
	GND	Power Source and Input Signal Common
	A, / A, B, / B, Z, / Z, U, / U, V, / V, W, / W	PG Signal Input Terminal (Line Driver Type), RS-422 Level Input
	AO, / AO, BO, / BO, ZO, / ZO	Pulse monitor output: Line Driver Type, RS-422 Level Input
	E	Grounding Terminal

Copy Unit

JN5-CU	Features
	<ul style="list-style-type: none"> ▲ Duplicating parameters setting in one AC drive to another AC drive. ▲ As a remote digital operator. ▲ Standard RJ45 network cable.

Cables

RJ45 to USB connecting cable		Features
JN5-CM-USB	1.8 meters	<ul style="list-style-type: none"> ▲ Using with the TECO exclusive PC-software. ▲ Make adjusting and copying parameters of AC drive through PC available.
JN5-CM-USB-3	3 meters	
		



Distributor

TECO
TECO ELECTRIC & MACHINERY CO., LTD.



10F, No. 3-1, Park St., Nan-Kang, Taipei 115, Taiwan
TEL : 886-2-6615-9111 Ext.1339 FAX : 886-2-6615-1033

<http://globalsa.teco.com.tw>

Specifications covered in this brochure may be subject to change without notice.

GJ-66-09 2015-11-10