



## 8 Important Information about Tables and Dimension Sheets

### 8.1 Geometrically possible combinations

#### Structure of the tables

These tables show combinations of gear units and AC (brake) motors that are geometrically possible. The following data are given for each combination and an input speed  $n_i = 1400$  1/min:

- Output speed ( $n_a$ )
- Maximum output torque ( $M_{amax}$ )
- Permitted overhung load ( $F_{Ra}$ ) at maximum output torque, applies to foot-mounted gear units with solid shaft
- Gear ratio (i)

Torsion angle  $\varphi_{(R)}$ : If no value is indicated, the gear unit is not available with "reduced backlash (/R)" with this option. If a value is stated, this gear unit is available with "reduced backlash (/R)". The numerical value specifies the circumferential backlash of the reduced backlash version in angular minutes ['].

R57, $n_e = 1400$ 1/min										450 Nm	
$n_a$ [1/min]	$M_{amax}$ [Nm]	$F_{Ra}$ [N]	$\varphi_{(R)}$ [']	i	DR63 DRS71S DRS71M	DRS80	DRS90M	DRS90L DRS100M	DRS100LC	DRS132S DRS132M	DRS132MC
2											
53	450	4750	6	26.31							
56	450	4640	6	24.99*							
64	450	4370	7	21.93							
75	450	4050	7	18.60*							

— Gear unit reduction ratio

No data (-): The reduced backlash (= /R) option is not possible for this i value.

Numerical value given: The reduced backlash (= /R) option is possible; the numerical value specifies the circumferential backlash of the reduced backlash version in angular minutes ['].

— Permitted overhung load at maximum output torque (foot-mounted gear unit with solid shaft)

— Maximum output torque

— Output speed

\* Finite gear unit reduction ratio

	Combination with the motor in the header <b>is possible</b> .
	Combination with the motor in the header <b>is not possible</b> .

Helical gear units (R), with the exception of the single stage RX gear unit, and parallel-shaft helical gear units (F) have two or three stages, depending on the gear unit reduction ratio. The tables indicate whether the subsequent i ranges are two or three stage. Multi-stage gear units always have a helical gear unit as their primary gear unit; it explains why the number of stages is also given for multi-stage gear units.



For R and F gear units: Number of stages of the subsequent gear ratios (two or three stage).

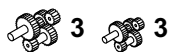

For multi-stage gear units: Stages of the following ratios (2-2, 3-3, 2-3 or 3-2 stages).

The number of stages of the primary gear unit (= small gear unit) is given on the right; the number of stages of the output gear unit (= large gear unit) is given on the left.

Helical-bevel, Spiroplan® and helical-worm gear units (K, W and S) have a defined number of stages. This means the number of stages does not have to be listed in the tables.

- Helical-bevel gear units (K): Always three-stage
- Spiroplan® gear units (W): W..10 to W..30: always single-stage W..37 and W..47: always two-stage
- Helical-worm gear units (S): always two-stage





## Important Information about Tables and Dimension Sheets

### Selection tables for gearmotors

#### 1. For extremely low output speeds (multi-stage gearmotors):

61030AXX

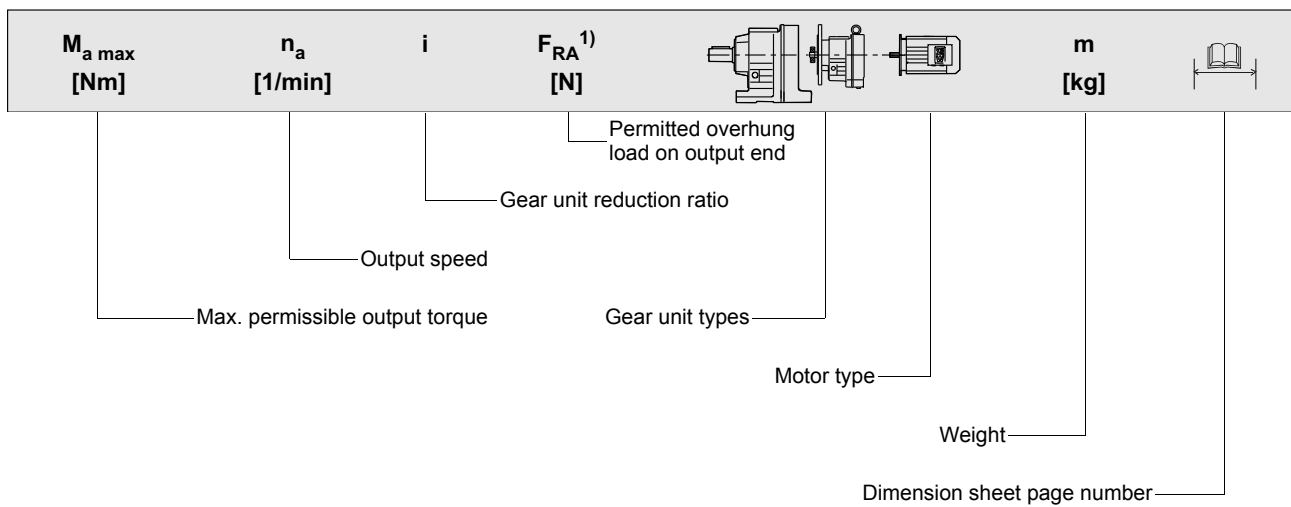

#### Key

- \* Finite gear unit reduction ratio
- 1) Overhung load for foot-mounted gear units with solid shaft; overhung loads for other gear unit types upon request



In drives for extremely low output speeds (multi-stage gearmotors), the motor power must be limited to the maximum permitted output torque of the gear unit.



### 8.3 Information regarding the dimension sheets

#### Scope of delivery



= Standard parts supplied by SEW-EURODRIVE.



= Standard parts not supplied by SEW-EURODRIVE.

#### Tolerances

##### Shaft heights

The following tolerances apply to the indicated dimensions:

$h \leq 250 \text{ mm}$  → -0.5 mm

$h > 250 \text{ mm}$  → -1 mm

**Foot-mounted gear units:** Check the mounted motor because it may project below the mounting surface.

##### Shaft ends

Diameter tolerance:

$\varnothing \leq 50 \text{ mm}$  → ISO k6

$\varnothing > 50 \text{ mm}$  → ISO m6

Center bores according to DIN 332, shape DR:

$\varnothing = 7...10 \text{ mm}$  → M3

$\varnothing > 10...13 \text{ mm}$  → M4

$\varnothing > 13...16 \text{ mm}$  → M5

$\varnothing > 16...21 \text{ mm}$  → M6

$\varnothing > 21...24 \text{ mm}$  → M8

$\varnothing > 24...30 \text{ mm}$  → M10

$\varnothing > 30...38 \text{ mm}$  → M12

$\varnothing > 38...50 \text{ mm}$  → M16

$\varnothing > 50...85 \text{ mm}$  → M20

$\varnothing > 85...130 \text{ mm}$  → M24

$\varnothing > 130 \text{ mm}$  → M30

Keys: according to DIN 6885 (domed type)

##### Hollow shafts

Diameter tolerance:

$\varnothing$  → ISO H7 measured with plug gauge

Keys: according to DIN 6885 (domed type)

Exception: Key for WA37 with shaft  $\varnothing 25 \text{ mm}$  according to DIN 6885-3 (low form)

##### Multiple-spline shafts

$D_m$  = Measuring roller diameter

$M_e$  = Check gauge

##### Flanges

Centering shoulder tolerance:

$\varnothing \leq 230 \text{ mm}$  (flange sizes A120...A300) → ISO j6

$\varnothing > 230 \text{ mm}$  (flange sizes A350...A660) → ISO h6

Up to 3 different flange dimensions are available for each size of helical gear unit, Spiroplan<sup>®</sup> gear unit, AC (brake) motor and explosion-proof AC (brake) motor. The dimension sheets show the possible flanges for the respective sizes.



## Important Information about Tables and Dimension Sheets

Information regarding the dimension sheets

### **Eyebolts, lifting eyes**

R07...R27 helical gear units, motors up to DR100 and the Spiroplan® gearmotors W..10 to W..30 are delivered without special transportation fixtures. All other gear units and motors are equipped with cast-on suspension eye lugs, screw-on suspension eye lugs or screw-on lifting eyebolts.

Gear unit/motor type	screw-on,		cast-on eyebolts
	lifting eyebolts	eyebolts	
R..37-R..57	-	•	-
R..67-R..107	•	-	-
RX57-RX67	-	•	-
RX77-RX107	•	-	-
F..27-F..157	-	-	•
K..37-K..157	-	-	•
K..167-K..187	•	-	-
S..37-S..47	-	•	-
S..57-S..97	-	-	•
W37-W47	-	•	-
≥ DR112	•	-	-

### **Breather valves**

The gear unit dimension drawings are shown with screw plugs. As standard, the corresponding screw plug is replaced with an activated breather valve depending on the ordered mounting position M1...M6. Contour dimensions might be slightly different as a result.

### **Shrink disk connection**

Hollow shaft gear unit with shrink disk connection: If required, please request a detailed data sheet on shrink disks, data sheet no. 33 753 ..95.

### **Splined hollow shaft**

FV.. hollow shaft gear units in sizes 27 ... 107 and KV.. in sizes 37 ... 107 are delivered with a splined hollow shaft according to DIN 5480 (tooth space tolerance 9H).

### **Rubber buffer for FA/FH/FV/FT**

Preload rubber buffer by the indicated value  $\Delta L$ . The characteristic curve of spring for the rubber buffers is available at SEW-EURODRIVE on request.

### **Torque arm position**

The following illustration shows the possible torque arm positions for helical-worm gear units and Spiroplan® gear units as well as the respective angles:

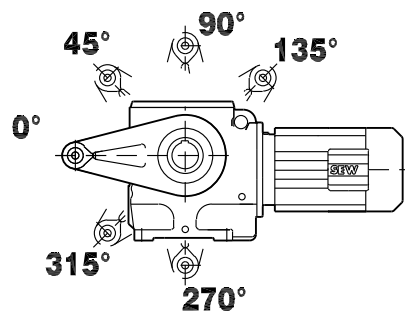

59253AXX

Figure 28: Torque arm position



**Dimensions for motors**

**Motor options** The motor dimensions may change due to motor options. Refer to the dimension drawings of the motor options.

**Special designs** The dimensions of the terminal box on special designs such as KS, CSA, VIK, low voltage or voltage changeover may deviate from the standard dimensions.

**EN 50347** European standard EN 50347 became effective in August 2001. This standard adopts the dimension designations for three-phase AC motors of size 56 to 315M and flange size 65 to 740 from the IEC 72-1 standard.

The new dimension designations given in EN 50347 / IEC 72-1 are used for the relevant dimensions in the dimension sheet tables.

**Dimension designations for motors**

The dimension designations for the motors are described below:

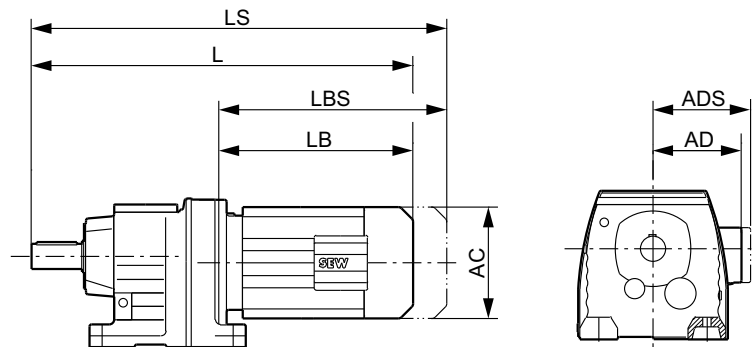

59251AXX

Figure 29: Dimension designations for the motors

- L = Total length of the gearmotor
- LS = Total length of the gearmotor including the brake
- LB = Length of the motor
- LBS = Length of the brakemotor
- AC = Diameter of the motor
- AD = Distance between the center of the motor shaft and the top part of the terminal box
- ADS = Distance between the center of the brakemotor shaft and the top part of the terminal box



**Important Information about Tables and Dimension Sheets**  
Information regarding the dimension sheets

---