



## Brake Solutions for Pitch- and Yaw Drives



# Precima FDW Pitch Brakes

- Specially designed, fully machined coil body for most efficient magnetic performance
- With sealing device the brake is completely sealed IP 66 / CCV Version for -40°C
- High performance non asbestos linings for precise torque control and extended life span
- Machined outer and inner diameters for accurate centralizing of brake
- Tapped bores for encoder mounting

## Options

- Inductive sensor for monitoring function
- Internal heating

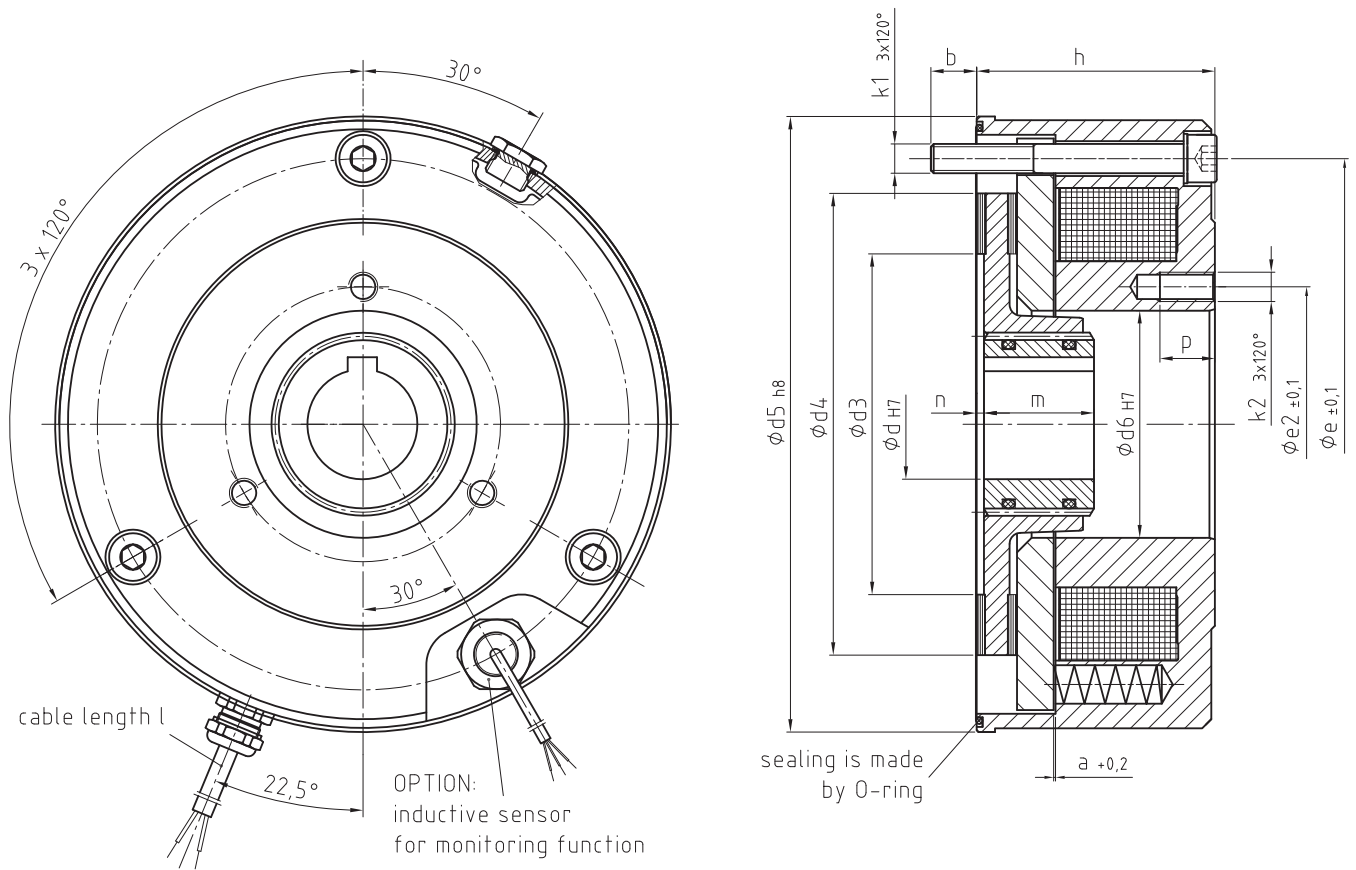

Size	Braking torque (Nm)	P 20 °C (Watt)	a (+0,2)	b	Toothed hub ød H7	ød3	ød4	ød5 (h8)	ød6 (H7)	øe (±0,1)	øe2 (±0,1)	h	k1 (3x120°)	k2 (3x120°)	l	m	n	p
FDW 15	80 / 60 / 50 / 40	63	0,3	12	20 / 25	80,5	117	158	52	132	65	60	M6x65	M6	600	25	3	12
FDW 17	120 / 100 / 80 / 60	78	0,3	12,5	25 / 30 / 35*	93	126	168	62	145	75	65	M8x70	M8	600	30	2	15
FDW 20	200** / 140 / 120	96	0,4	14	30 / 35 / 40	118	152	199	72	170	85	81	M8x85	M8	600	30	3	15

Dimensions in mm, Standard keyway in accordance with DIN 6885/1-JS9

\*) Keyway in accordance with DIN 6885/3-JS9, \*\*) Operated with rectifier PMG 500

# Precima FDB/ FDW Yaw Drive Brakes

- FDB brakes also as C version for fine torque adjustment
- FDB brakes: re-adjustable air gap to compensate for wear
- FDB brakes: IP 54 / FDW brakes: IP 66 / CCV version for -40°C
- Heavy duty: high temperature friction linings for longer life

**Options:**

- Tapped bores for encoder mounting
- Internal heating
- PT100 temperature indicator
- Inductive sensor or micro switch for monitoring function
- Manual hand release
- Hard-coated friction surface

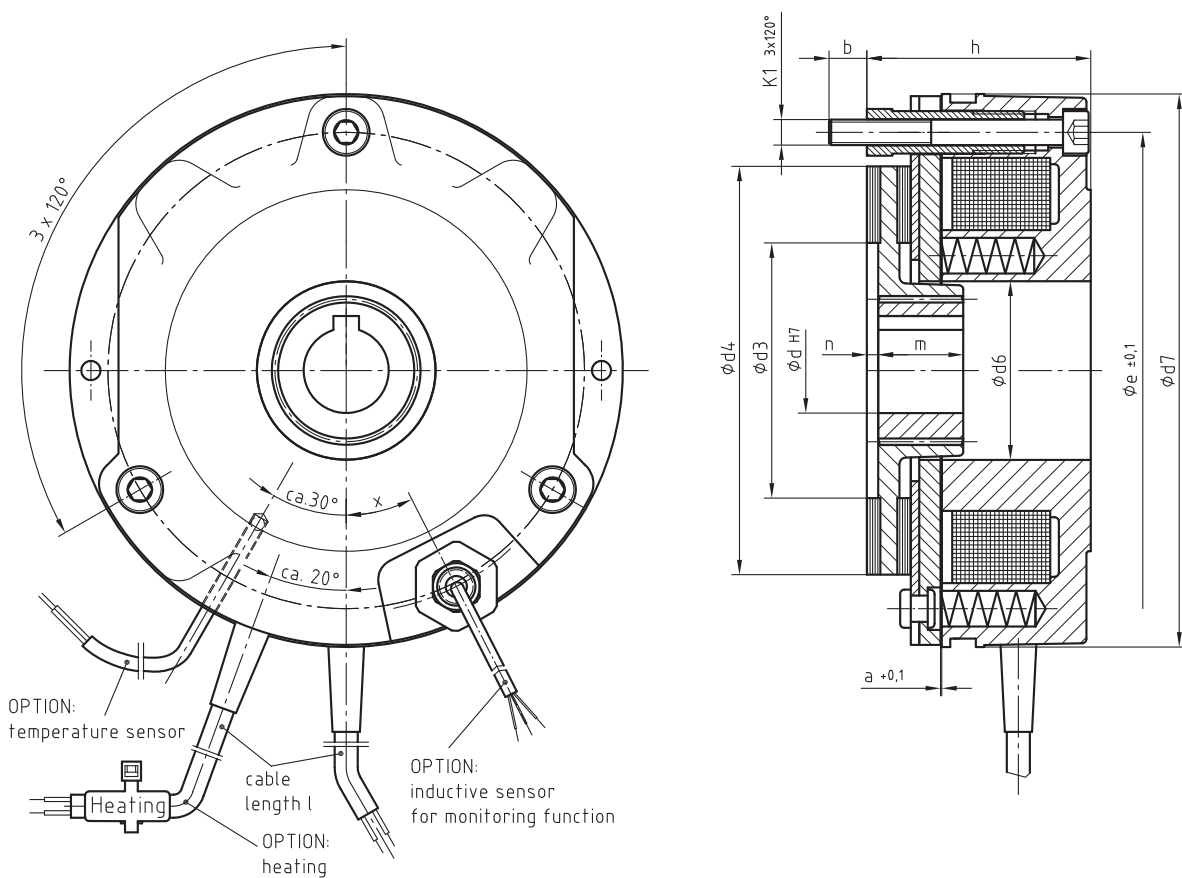

Size	Braking torque (Nm)	P 20 °C (Watt)	a (+0,1)	b	Toothed hub ød H7	ød3	ød4	ød6	ød7	øe (±0,1)	h	k1 (3x120°)	l	m	n	x
FDB 13	30 / 20	34	0,3	8,8	15 / 20	62	96	42	130	112	52,7	M6x55	500	20	3,5	27°
FDB 15	60 / 40	42	0,3	8,8	20 / 25	80	118,5	52	150	132	60,2	M6x65	600	25	3	22°
FDB 17	90 / 60	50	0,3	10	25 / 30 / 35*	84	127,5	62	170	145	70	M8x70	600	30	3	25°
FDB 20	150 / 100	76	0,4	10	30 / 35 / 40	94	152	72	195	170	80,5	M8x85	600	30	3	35°

Dimensions in mm, Standard keyway in accordance with DIN 6885/1-JS9

\*) Standard keyway in accordance with DIN 6885/3-JS9



Headquarters and Assembly Line at Bückeberg-Röcke



Plant II - CNC Production at Bückeberg-Müdingen



## Company Information:

Precima Magnettechnik GmbH was founded in the year 1981 and is today established as an independent, medium sized, innovative family owned brake manufacturer. With our staff of more than 150 employees we develop and produce a wide range of electro-magnetic operated brakes and clutches for all kinds of applications in machine and other industries. Our standard range of products covers a performance scope of braking torques between 0.5 and 1,500 Nm.

Thanks to our advanced CNC machining technology and well organized assembly lines we produce more than 500,000 units per year. The high rate of self manufactured parts provides us with a maximum of flexibility and allows for short response times. Our own highly qualified and experienced engineering and development departments are specialized in producing customized brake solutions on a very high technical and economic standard.



### PRECIMA MAGNETTECHNIK GmbH

Röcker Straße 16  
31675 Bückeberg / Germany  
Tel.: ++49(0)5722 89332-0  
Fax: ++49(0)5722 89332-2  
E-Mail: [info@precima.de](mailto:info@precima.de)

[www.precima.de](http://www.precima.de)