



A510_s

Advanced Current Vector Control Drive





A510^{Super}

Super represents

Super technology
 Super excellence
 Super evolution

The super evolution of A510s made it debut which combined customer responses with Innovation. Advanced current vector control inverter - A510s. Except the Auto-tuning and support for the PM motor, the core computing of A510s raises to 60%. The all new technologies make our inverters better. Please feel the charming of A510s.

A510s



A510s

7 types of motor controls

A510s can support many industries such as elevator, crane and compressor

Auto-tuning support

Advanced Rotational、Static and Stator resistance Auto-tuning modes

Wide range of applications

Easily transfer to specific parameters for dedicated application
16 V/F curves for wide range of applications

High level sensor vector mode

Support to induction motor and permanent magnet motor
A510s promotes motors to optimum condition

Much faster for computing ability

Dual core processors
Faster computing ability, Larger ROM and RAM.

Conformity to global standards

RoHS、CE、UL
Provide safety function such as fire mode

DUAL CORE PROCESSORS

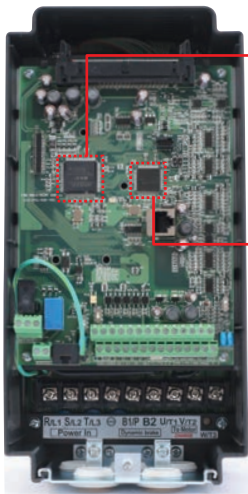

ASIC *Above frame2 models
Prevents inrush current damage to IGBT module. Enhances the reliability and life expectancy of motor drive.

32Bit MCU
Mass computing capability for advanced current vector control technology. Minimizes the internal loop time for higher control response.

Enhanced Performance & Reliability!

More powerful in core computing

- New core processors and better computing ability

Core computing **Raise 60%**

Raise **100%** ROM

RAM **Raise 530%**

*Compare with A510

ADVANCED MOTOR AUTO-TUNE FUNCTION

Multiple Auto-tune Modes

Rotational auto-tune mode	Rotary-type auto-tune for higher performance for precise control.
Static auto-tune mode	The motor shaft will be locked in static auto-tune mode.
Stator resistance measurement	Auto measure the resistor within cable and compensate accordingly.

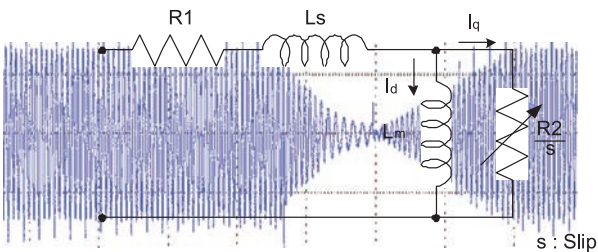

Motor Equivalent Circuit

5th
Kernel

A510s is loaded with 5th generation kernel has the most advanced motor tuning function to build accurate motor equivalent model automatically.

Optimized current vector control performance provides faster commissioning.

200% 0.5Hz STARTING TORQUE

SensorLess Vector (SLV) control mode achieves incredible 200% torque performance at extreme low speed 0.5Hz. Provides stable control experience for wide range of applications.

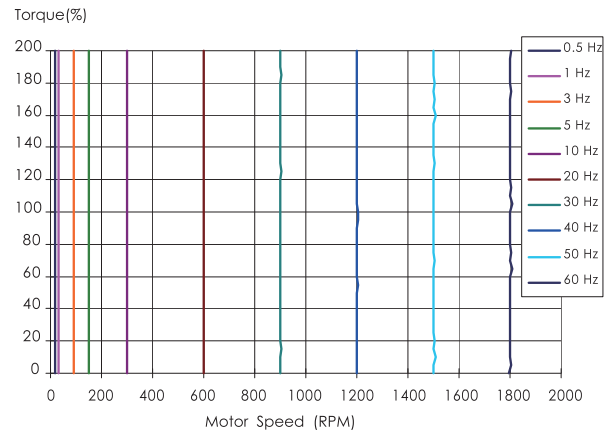

Sensor Vector Mode (SV) can output 200% holding torque.

CONFORMITY TO GLOBAL STANDARDS

- Conformity to RoHS directive and international recognized certification

RoHS



HIGH EFFICIENCY PM MOTOR DRIVING

- Simple parameter settings for easy switching between induction and permanent magnet motors.
- High performance current vector control for induction and permanent magnet motors.

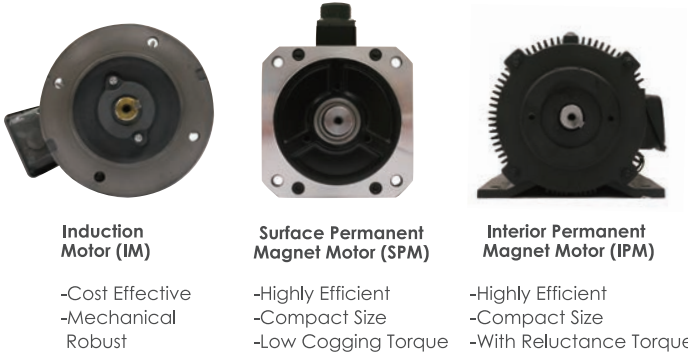

FAN CONTROL AND QUICK RELEASE

- Lower noise and extend the life of fan.
- Quick replaceable fan makes customers be easy to change it.



Multilanguage

- Parameters of Multilanguage are essential for international product and minimize the language barrier

ULTRA LOW MOTOR NOISE

Traditional PWM modulation method

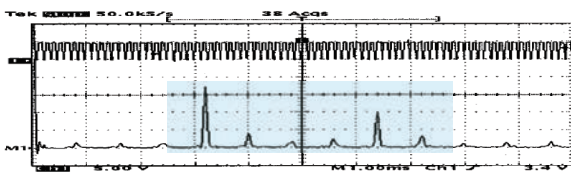

Unique Soft PWM modulation technology lowers the audible motor noise for quieter industrial environment

Soft PWM modulation method

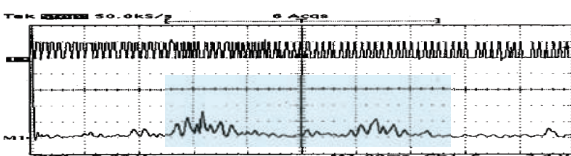

INTELLIGENT OVER VOLTAGE SUPPRESSION

- Suppress over voltage caused by regenerative loads and redirect regenerative energy back to the load. Intelligent overvoltage suppression will not only protect the drive but also no need for costly braking units.

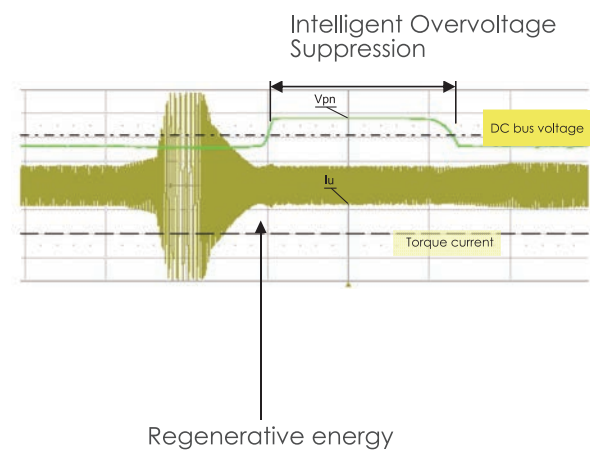

The Complete Motor Control Solution

with powers for a wide range of applications



Gravitational Handling Equipment

| Crane, Elevator

Metal Processing Machine

| Press, Lathes

Plastics/Rubber Processing Machine

| Extruder, Injection Molding Machine

Tension Control Equipment

| Printing Machine, Reeling Machine

Textile Machine

| Dyeing and Finishing Machine

Wire/Cable Making Machine

| Wire Drawing Machine

SELECTION GUIDE

Dual rating design for heavy duty and normal duty applications.

ND. Selection Guide
Overload Capability Up To 120%/60sec

Driving higher horsepower motor in normal duty mode includes fans, pumps, HVAC, etc.

Example:
 Select A510-2002-SH model for 3HP motor in pump application. Sets 00-27=1 (ND Mode)
 *Motor parameters need to be adjusted.

HD. Selection Guide
Overload Capability Up To 150%/60sec and 200%/2sec

Driving the same horsepower motor in heavy duty mode includes lifts, press, machine tools, etc.

Example:
 Select A510-2015-SH3 model for 15HP motor in conveyor application. Sets 00-27=0 (HD Mode)

Maximum Applicable Motor (HP) (kW)		Three-Phase 200V				Three-Phase 400V			
		Normal Duty (ND)		Heavy Duty (HD)		Normal Duty (ND)		Heavy Duty (HD)	
		A510s Model	Rated Output Current	A510s Model	Rated Output Current	A510s Model	Rated Output Current	A510s Model	Rated Output Current
1	0.75			A510-2001-SH	5A			A510-4001-SH3(F)	3.4A
1.5	1.1	A510-2001-SH	6A						
2	1.5			A510-2002-SH	8A	A510-4001-SH3(F)	4.1A	A510-4002-SH3(F)	4.2A
3	2.2	A510-2002-SH	9.6A	A510-2003-SH	11A	A510-4002-SH3(F)	5.4A	A510-4003-SH3(F)	5.5A
5	3.7	A510-2003-SH	12A	A510-2005-SH3	17.5A	A510-4003-SH3(F)	6.9A	A510-4005-SH3(F)	9.2A
7.5	5.5	A510-2005-SH3	22A	A510-2008-SH3	25A	A510-4005-SH3(F)	12.1A	A510-4008-SH3(F)	14.8A
10	7.5	A510-2008-SH3	30A	A510-2010-SH3	33A	A510-4008-SH3(F)	17.5A	A510-4010-SH3(F)	18A
15	11	A510-2010-SH3	42A	A510-2015-SH3	47A	A510-4010-SH3(F)	23A	A510-4015-SH3(F)	24A
20	15	A510-2015-SH3	56A	A510-2020-SH3	60A	A510-4015-SH3(F)	31A	A510-4020-SH3(F)	31A
25	18.5	A510-2020-SH3	69A	A510-2025-SH3	73A	A510-4020-SH3(F)	38A	A510-4025-SH3(F)	39A
30	22	A510-2025-SH3	80A	A510-2030-SH3	85A	A510-4025-SH3(F)	44A	A510-4030-SH3(F)	45A
40	30	A510-2030-SH3	110A	A510-2040-SH3	115A	A510-4030-SH3(F)	58A	A510-4040-SH3(F)	60A
50	37	A510-2040-SH3	138A	A510-2050-SH3	145A	A510-4040-SH3(F)	73A	A510-4050-SH3(F)	75A
60	45	A510-2050-SH3	169A	A510-2060-SH3	180A	A510-4050-SH3(F)	88A	A510-4060-SH3(F)	91A
75	55	A510-2060-SH3	200A	A510-2075-SH3	215A	A510-4060-SH3(F)	103A	A510-4075-SH3	118A
100	75	A510-2075-SH3	250A	A510-2100-SH3	283A	A510-4075-SH3	145A	A510-4100-SH3	150A
125	94	A510-2100-SH3	312A	A510-2125-SH3	346A	A510-4100-SH3	168A	A510-4125-SH3	180A
150	112	A510-2125-SH3	400A	A510-2150-SH3	415A	A510-4125-SH3	208A	A510-4150-SH3	216A
175	130	A510-2150-SH3	450A			A510-4150-SH3	250A	A510-4175-SH3	260A
215	160					A510-4175-SH3	296A	A510-4215-SH3	295A
250	185					A510-4215-SH3	328A	A510-4270-SH3	380A
270	200					A510-4270-SH3	435A		
300	220							A510-4300-SH3	450A
335	250					A510-4300-SH3	515A		
375	280							A510-4375-SH3	523A
425	315					A510-4375-SH3	585A	A510-4425-SH3	585A

Model Identification

A510	-	2		001	-	S		H		3		F
		Input Voltage			Horse Power	A510s Series		Type	Power Supply		Noise Filter	
		2 : 200V Class 4 : 400V Class 5 : 575V Class 6 : 690V Class			001 : 1HP 425 : 425HP			H : Standard Type (LED Display) C : Graphic Type (LCD Display)	Blank : Single/Three-Phase 3 : Three-Phase		Blank : None F : Built-in	

WIRING DIAGRAM

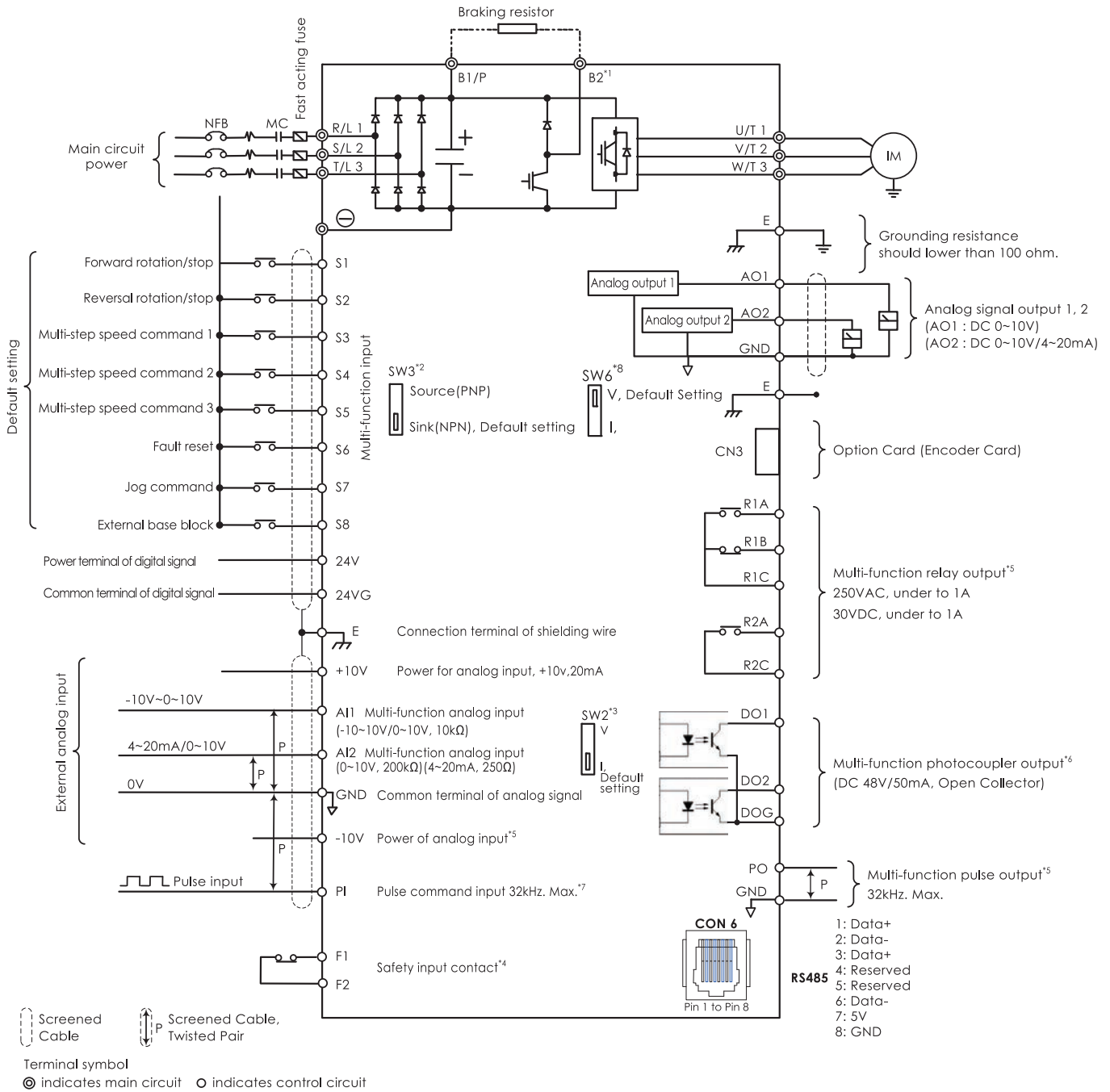

BASIC SPECIFICATIONS

200V Class

Inverter Capacity (HP)			1	2	3	5	7.5	10	15	20	25	30	40	50	60	75	100	125	150	
Output Rating	HD*3	Rated Output Capacity (KVA)	1.9	3	4.2	6.7	9.5	12.6	17.9	22.9	27.8	32.4	43.8	55.3	68.6	81.9	108	132	158	
		Rated Output Current (A)	5	8	11	17.5	25	33	47	60	73	85	115	145	180	215	283	346	415	
		Maximum Applicable Motor*1 HP (KW)	1 (0.75)	2 (1.5)	3 (2.2)	5 (3.7)	7.5 (5.5)	10 (7.5)	15 (11)	20 (15)	25 (18.5)	30 (22)	40 (30)	50 (37)	60 (45)	75 (55)	100 (75)	125 (90)	150 (110)	
	ND*4	Rated Output Capacity (KVA)	2.3	3.7	4.6	8.4	11.4	16.0	21.3	26.3	30.1	41.9	52.6	64.4	76.2	95.3	118.9	152.4	172	
		Rated Output Current (A)	6	9.6	12	22	30	42	56	69	80	110	138	169	200	250	312	400	450	
		Maximum Applicable Motor*1 HP (KW)	2 (1.5)	3 (2.2)	5 (3.7)	7.5 (5.5)	10 (7.5)	15 (11)	20 (15)	25 (18.5)	30 (22)	40 (30)	50 (37)	60 (45)	75 (55)	100 (75)	125 (90)	150 (110)	175 (130)	
Maximum Output Voltage (V)		Three-Phase, 200V to 240V																		
Maximum Output Frequency (Hz)		Based on parameter setting 0.1~599Hz																		
Input Power	Rated Voltage, Frequency		Single/Three-Phase, 200V to 240V, 50/60Hz			Three-Phase, 200V to 240V, 50/60Hz														
	Allowable Voltage Fluctuation		-15% ~ +10%																	
	Allowable Frequency Fluctuation		±5%																	
Braking Transistor		Built-in									Option (Braking Module)									
Frame Size		1	2	3	4	5	6	7	8											

400V Class

Inverter Capacity (HP)			1	2	3	5	7.5	10	15	20	25	30	40	50	60	75	100	125	150	175	215	215H	270	300	375	425	
Output Rating	HD*3	Rated Output Capacity (KVA)	2.6	3.2	4.2	7	11.3	13.7	18.3	23.6	29.7	34.3	45.7	57.2	69.3	89.9	114	137	165	198	225	251	290	343	400	461	
		Rated Output Current (A)	3.4	4.2	5.5	9.2	14.8	18	24	31	39	45	60	75	91	118	150	180	216	260	295	330	380	450	523	585	
		Maximum Applicable Motor*1 HP (KW)	1 (0.75)	2 (1.5)	3 (2.2)	5 (3.7)	7.5 (5.5)	10 (7.5)	15 (11)	20 (15)	25 (18.5)	30 (22)	40 (30)	50 (37)	60 (45)	75 (55)	100 (75)	125 (90)	150 (110)	175 (132)	215 (160)	215 (160)	270 (200)	300 (220)	375 (280)	425 (315)	
	ND*4	Rated Output Capacity (KVA)	3.1	4.1	5.3	9.2	13.3	17.5	23.6	29.0	33.5	44.2	55.6	67.1	78.5	111	128	159	191	226	250	282	332	393	446	446	
		Rated Output Current (A)	4.1	5.4	6.9	12.1	17.5	23	31	38	44	58	73	88	103	145	168	208	250	296	328	370	435	515	585	585	
		Maximum Applicable Motor*1 HP (KW)	2 (1.5)	3 (2.2)	5 (3.7)	7.5 (5.5)	10 (7.5)	15 (11)	20 (15)	25 (18.5)	30 (22)	40 (30)	50 (37)	60 (45)	75 (55)	100 (75)	125 (90)	150 (110)	175 (132)	215 (160)	250 (185)	270 (200)	300 (220)	375 (280)	425 (315)	425 (315)	
Maximum Output Voltage (V)		Three-Phase, 380V to 480V																									
Maximum Output Frequency (Hz)		Based on parameter setting 0.1~599Hz																									
Input Power	Rated Voltage, Frequency		Three-Phase, 380V to 480V, 50/60Hz																								
	Allowable Voltage Fluctuation		-15% ~ +10%																								
	Allowable Frequency Fluctuation		±5%																								
Braking Transistor		Built-in									Option (Braking Module)																
Frame Size		1	2	3	4	5	6	7	8																		

Notes:

- Based on the standard 4-pole induction motor. The selected inverter must have a higher output current rating than the motor.
- The default setting of A510s takes HD (heavy duty mode) as the base. To switch A510s to ND (normal duty mode) set parameter (00-27) to 1. When switching to ND (normal duty mode), the frequency will change to 2kHz.
- The default setting of carrier frequency in HD mode is shown in right side table, if the setting value is higher than default setting, de-rating may be required.
- The default setting of carrier frequency in ND mode is 2kHz, if the setting value is higher than default setting, de-rating may be required.
- If control mode is set to SLV mode and maximum frequency is larger than 80Hz, the carrier frequency range is 2~8kHz.

Inverter Voltage and Capacity		HD mode carrier freq range	HD mode carrier freq default setting
200V Class	400V Class		
1~20HP	1~30HP	2~16kHz	8kHz
25HP	-	2~12kHz	6kHz
30~40HP	40~50HP	2~12kHz*5	5kHz
50~100HP	60~175HP	2~10kHz*5	5kHz
-	125HP	2~10kHz	4kHz
-	215HP	2~8kHz	3kHz
125~150HP	-	2~5kHz	5kHz
-	270~375HP	2~5kHz	4kHz
-	425HP	2~5kHz	2kHz

GENERAL SPECIFICATIONS

Control Characteristics	Display	LED keypad with 5-digits seven-segment display (LCD keypad option)
	Control Modes	V/F, V/F+PG, SLV, SLV2, SV, PMSV, PMSLV (SVPWM Modulation)
	Output Frequency	0.1Hz~599Hz
	Frequency Accuracy	Digital references: $\pm 0.01\%$ (-10 to +40°C), Analog references: $\pm 0.1\%$ (25°C $\pm 10^\circ\text{C}$)
	Speed Control Accuracy ^{*2}	$\pm 0.1\%$ (Sensor Vector Control Mode, SV) $\cdot \pm 0.5\%$ (Sensorless Vector Control Mode, SLV)
	Frequency Setting Resolution	Digital References: 0.01Hz, Analog References: 0.03Hz at 60Hz
	Output Frequency Resolution	0.01Hz
	Overload Tolerance	Heavy Duty Mode (HD.) : 150% rated current for 60sec, 200% rated current for 2 sec. (Factory default) Normal Duty Mode (ND.) : 120% rated current for 60sec
	Frequency Setting Signal	0 to +10V, -10V to +10V, 4 to 20mA or pulse train input
	Acceleration / Deceleration Time	0.0~6000.0 sec (separately set acceleration and deceleration time)
	Voltage / Frequency Characteristics	15 fixed and one customized v/f pattern
	Braking Torque	Approximate 20% (Built-in braking transistors under 200V 25HP and 400V 40HP)
	Main Control Functions	Auto-tuning, Zero Servo, Torque Control, Position Control, Droop, Soft-PWM, Over-Voltage Protection, Dynamic Braking, Speed Search, Frequency Traversing, Momentary Power Loss Restart, PID Control, Automatic Torque Compensation, Slip Compensation, RS-485 Communication, Close Loop Control with PG, Simple PLC Function, Two Analog Output, Safety input contact
Other Functions	Records of Power ON and Operation Time, 30 Fault History Records and Latest Fault State Record, Energy-Saving Function, Phase Loss Protection, DC Braking, Dwell, S Curve Acceleration and Deceleration, Up / Down Operation, Modbus Communication Protocol, Output of Pulse Multiple, Display of Engineering Unit, SINK / SOURCE Selection	
Protection Functions	Stall Prevention	Current level can be adjusted. (In acceleration or constant speed, it can be set separately. In deceleration, it can be set with or without stall protection)
	Over Current (OC) and Output Short-Circuit (SC) Protection	It stops when the current exceeds 200% of the inverter rated current.
	Inverter Overload Protection (OL2)	Inverter will be stopped when the output is higher than below conditions. Heavy Duty Mode (HD.) : 150% rated current for 60sec, 200% rated current for 2 sec. (Factory default), Carrier frequency is from 2kHz to 8kHz. Normal Duty Mode (ND.) : 120% rated current for 60sec, Carrier frequency is 2kHz.
	Motor Overload Protection (OL1)	Electrical overload protection curve
	Over Voltage Protection (OV)	If the main circuit DC voltage is over 410V (200V class) / 820V (400V class), the motor stops running.
	Under Voltage (UV)	If the main circuit DC voltage is under 190V (200V class) / 380V (400V class), the motor stops running.
	Momentary Power Loss Restart	Power loss exceeds 15ms You can set the function of momentary power loss restart to up to 2 sec
	Overheat Protection (OH)	Thermistor sensor on heatsink
	Ground Fault Protection (GF)	Protection by current detection circuit
	Charge Indicator	When main circuit DC voltage $\geq 50\text{V}$, the CHARGE LED is on.
	Output Phase Loss Protection (OPL)	If the OPL function acts, the motor stops rotation automatically
	Location	Indoor (Protected from corrosive gases and dust)
	Environment Specification	Ambient Temperature
Storage Temperature		-20~+70°C
Humidity		95%RH or less (no condensation)
Altitude and Vibration		Altitude of 1000 meters or lower ; 1.0G, in compliance with IEC 60068-2-6
Pollution Degree		Meet IEC 60721-3-3 Class 3C2
Communication Function	Built-in RS-485 as standard (Modbus protocol with standard RJ45)	
Electromagnetic Interference (EMI)	In compliance with EN61800-3 standard, 400V 60HP or below can be built in.	
Electromagnetic Compatibility (EMS)	In compliance with EN61800-3 standard	
Certification	CE	In compliance with EN61800-3 (CE & RE) and EN61800-5-1 (LVD)
	UL	UL508C
Option Card	Open collector type(IM) , line driver type(IM) and Line driver type for PM motor	

Notes:

*1. A510s IP21 is for option, if there's any need, please contact TECO salesman.

*2. Speed control accuracy will be influenced when the motor and installation condition are different.

DIMENSIONS

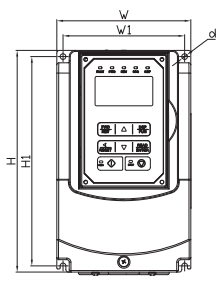

Figure A

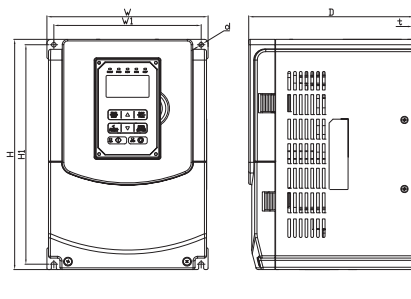

Figure B

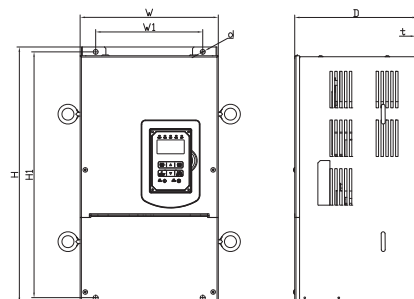

Figure C

Figure	Enclosure	Frame	Models	Dimensions (mm)							
				W	H	D	W1	H1	t	d	Weight (kg)
A	IP20	Frame 1	A510-2001-SH	130	215	150	118	203	5	M5	2.2
			A510-2002-SH								
			A510-4001-SH3								
			A510-4002-SH3								
			A510-4003-SH3								
B	IP20	Frame 2	A510-2003-SH	140	279	177	122	267	7	M6	3.8
			A510-2005-SH3								
			A510-2008-SH3								
			A510-4005-SH3								
			A510-4008-SH3								
		Frame 3	A510-2010-SH3	210	300	215	192	286	1.6	M6	6.2
			A510-4010-SH3								
			A510-4015-SH3								
			A510-4020-SH3								
			A510-2015-SH3								
Frame 4	A510-2020-SH3	265	360	225	245	340	1.6	M8	10		
	A510-2025-SH3										
	A510-4025-SH3										
	A510-4030-SH3										
	A510-2030-SH3										
C	IP20	Frame 5	A510-2030-SH3	286.5	525	252	220	505	3.3	M8	30
			A510-2040-SH3								
			A510-4040-SH3								
			A510-4050-SH3								
			A510-4060-SH3								
			A510-4075-SH3								

DIMENSIONS

Figure D

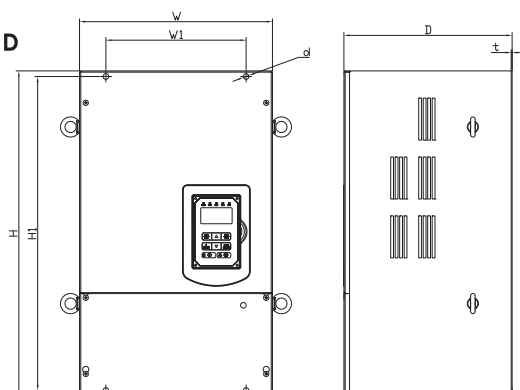

Figure E

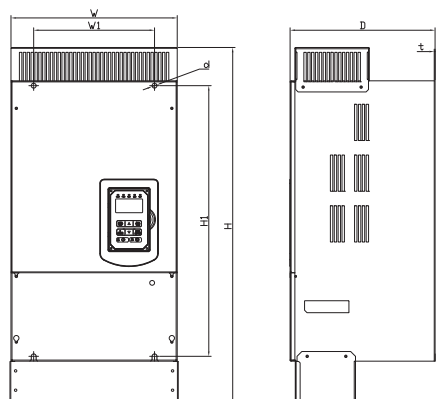

Figure	Enclosure	Frame	Models	Dimensions (mm)							Weight (kg)
				W	H	D	W1	H1	t	d	
D	IP00	Frame 6	A510-2050-SH3	344	580	300	250	560	1.6	M8	46.7
			A510-2060-SH3								
			A510-4100-SH3								
			A510-4125-SH3								
E	IP20	Frame 6	A510-2050-SH3	348.5	740	300	250	560	1.6	M8	49.7
			A510-2060-SH3								
			A510-4100-SH3								
			A510-4125-SH3								
D	IP00	Frame 7	A510-2075-SH3	459	790	324.5	320	760	1.6	M10	88
			A510-2100-SH3								
			A510-4150-SH3								
			A510-4175-SH3								
E	IP20	Frame 7	A510-2075-SH3	463.5	1105	324.5	320	760	1.6	M10	94.4
			A510-2100-SH3								
			A510-4150-SH3								
			A510-4215-SH3								

DIMENSIONS

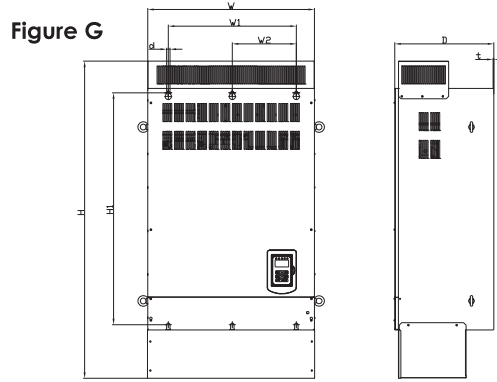
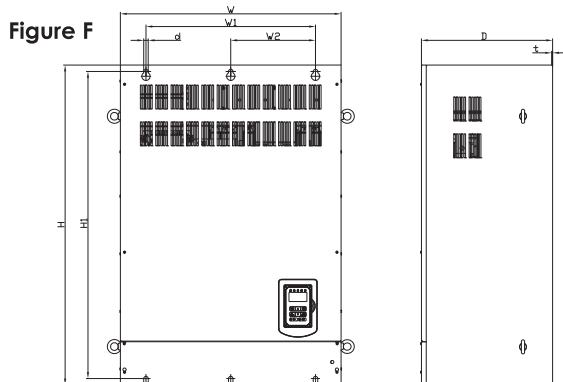

Figure	Enclosure	Frame	Models	Dimensions (mm)								
				W	H	D	W1	W2	H1	t	d	Weight (kg)
F	IP00	Frame 8	A510-2125-SH3	690	1000	410	530	265	960	2	M12	184
			A510-2150-SH3									
			A510-4215-SH3H									
			A510-4270-SH3									
			A510-4300-SH3									
			A510-4375-SH3									
A510-4425-SH3												
G	IP20	Frame 8	A510-2125-SH3	692	1313	410	530	265	960	2	M12	196
			A510-2150-SH3									
			A510-4215-SH3H									
			A510-4270-SH3									
			A510-4300-SH3									
			A510-4375-SH3									
A510-4425-SH3												

* The enclosure type of IP00 model is standard for frame 6 to frame 8. It is required to purchase the installation accessories if user selects the enclosure type of IP20 model.

Frame 6	JN5-NK-A06
Frame 7	JN5-NK-A07
Frame 8	JN5-NK-A08

DIMENSIONS

Figure H

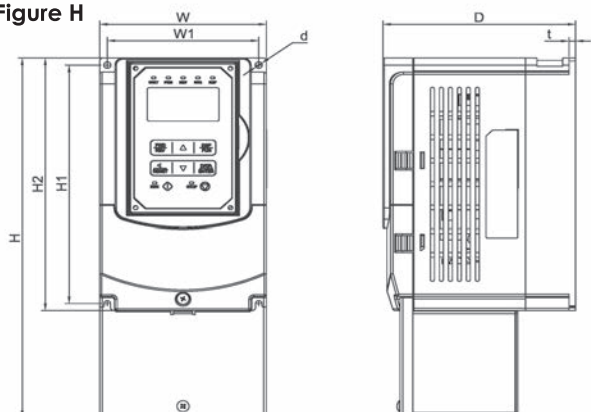

Figure	Enclosure	Frame	Models	Dimensions (mm)								
				W	H	D	W1	H1	H2	t	d	Weight (kg)
H	IP20	Frame 1	A510-4001-SH3F	130	306	150	118	203	215	5	M5	3.5
			A510-4002-SH3F									
			A510-4003-SH3F									
		Frame 2	A510-4005-SH3F	140	400	177	122	267	279	7	M6	5.5
			A510-4008-SH3F									

Figure I

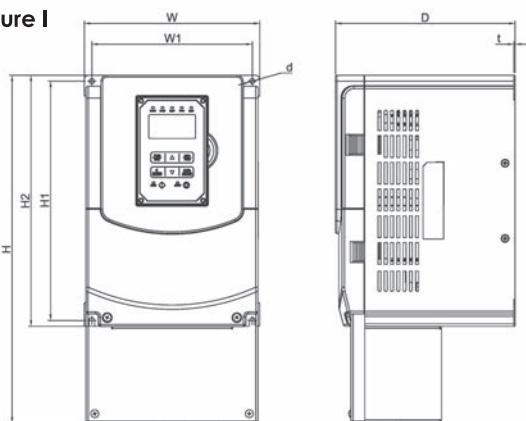

Figure J

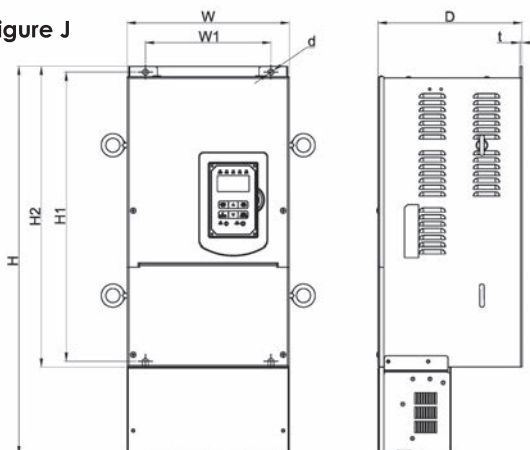

Figure	Enclosure	Frame	Models	Dimensions (mm)								
				W	H	D	W1	H1	H2	t	d	Weight (kg)
I	IP20	Frame 3	A510-4010-SH3F	210	416.5	215	192	286	300	1.6	M6	8.0
			A510-4015-SH3F									
		Frame 4	A510-4020-SH3F	265	500	225	245	340	360	1.6	M8	12.5
			A510-4025-SH3F									
			A510-4030-SH3F									
J	Frame 5	A510-4040-SH3F	286.5	679	252	220	505	525	3.3	M8	32.5	
A510-4050-SH3F												
A510-4060-SH3F												

ACCESSORIES

Accessories	Description	Model	Note
Cables	IP20 Digital operator extention cable	JN5-CB-01M	1 meter
		JN5-CB-02M	2 meter
		JN5-CB-03M	3 meter
		JN5-CB-05M	5 meter
	RJ45 to USB connecting cable	JN5-CM-USB	1.8 meter
Communication Moduels (Gateways)	Profibus DP module	JN5-CM-PDP	
	TCP-IP module	JN5-CM-TCPIP	
	DeviceNet module	JN5-CM-DNET	
	CANopen module	JN5-CM-CAN	
NEMA1 Kits	Mechanical device consisting of anti-dust cover on the upper part and wiring box on the bottom to meet NEMA1	JN5-NK-A06	For Frame 6
		JN5-NK-A07	For Frame 7
		JN5-NK-A08	For Frame 8
Digital Operators	IP20 LED Type	JN5-OP-A04	
	IP20 LCD Type	JN5-OP-A02	
	IP20 Blank type	JN5-OP-A03	
Protective Cover	Positioned on both sides of the inverter to prevent unknown objects from invading	JN5-CR-A01	For Frame 1
		JN5-CR-A02	For Frame 2
		JN5-CR-A04	For Frame 4
Others	Copy Module for 510 series	JN5-CU	

Encoder Feedback Card

ITEM	Encoder/Resolver Input Type	Output Type	Drive Installation	
			SIZE 1	>= SIZE 2
JN5-PG-O	Open collector feedback card	Open Collector	Yes	Yes
JN5-PG- L	Line driver speed feedback card	Line Driver	Yes	Yes
JN5-PG- L -24	Line driver speed feedback card	Open Collector	Yes	Yes
JN5-PG-PM	Synchronous motor line driver speed feedback card	Line Driver	No	Yes
JN5-PG-PMR	Speed feedback card with TAMAGAWA Resolver	Line Driver	No	Yes
JN5-PG-PMS	Speed feedback card with Heidenhain ERN 1387 Encoder Sin-Cos Incremental Encoder	Line Driver	No	Yes
JN5-PG-PMS-24	Speed feedback card with Heidenhain ERN 1387 Encoder Sin-Cos Incremental Encoder	Open Collector	No	Yes
JN5-PG-PMC	Speed feedback card with Heidenhain ECN 1313 Encoder 8192 (13bits) Absolute Encoder	Line Driver	No	Yes
JN5-PG-PMC-24	Speed feedback card with Heidenhain ECN 1313 Encoder 8192 (13bits) Absolute Encoder	Open Collector	No	Yes



Distributor

TECO

TECO ELECTRIC & MACHINERY CO., LTD.

10F, No. 3-1, Park St., Nan-Kang, Taipei 115, Taiwan

TEL : 886-2-6615-9111 Ext.1725

FAX : 886-2-6615-1033

<http://globalsa.teco.com.tw>

Specifications covered in this brochure may be subject to change without notice.



GJ-77-03 2017-02-20